

SPECIFICATIONS

REVELER

Fireclay Collection



TOP VIEW

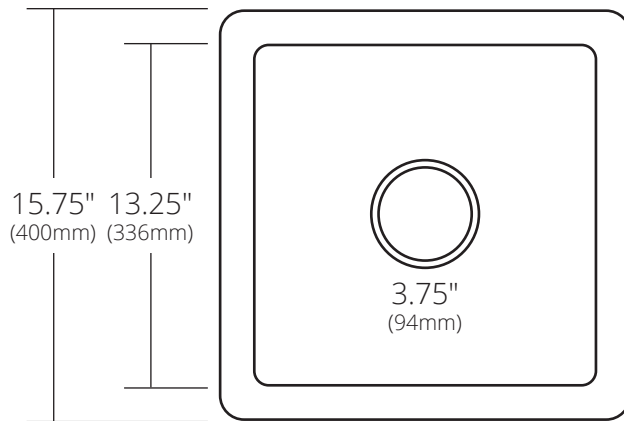

FRB1515-W White

PRODUCT DETAILS

- 15.75" x 15.75" x 7.5" OD (400mm x 400mm x 190mm)
- 13.25" x 13.25" x 6.75" ID (336mm x 336mm x 169mm)
- 3.75" (94mm) drain opening

INSTALLATION

- Undermount
- Install with negative reveal or flush mount

COORDINATING PRODUCTS

- Drains: DR320 or DR340 (extended flange not required)
- Bottom Grid: GRD934
- UK1426 Undermount Kit

STANDARDS COMPLIANCE

- UPC/cUPC compliant

IMPORTANT

Due to the handcrafted nature of this product, dimensions may vary up to 1/2" (13mm). We strongly recommend waiting for the actual product before making any installation cuts.

SIDE VIEW

