

SPECIFICATIONS

NIPOMO

NativeStone® Collection



TOP VIEW

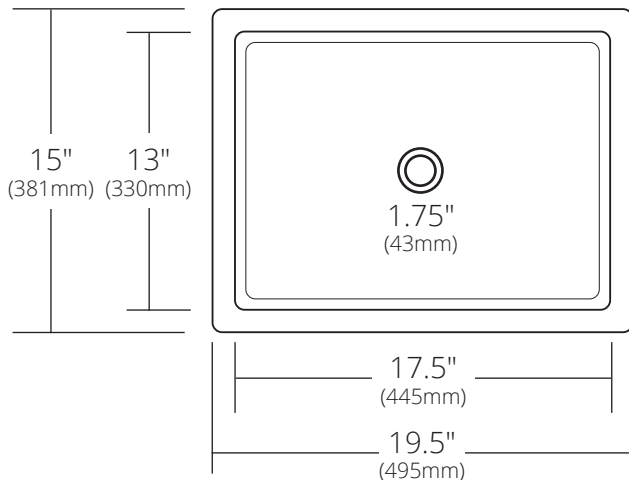

FRONT VIEW

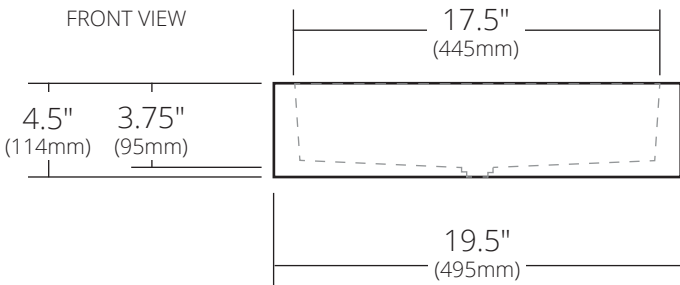

- NSL1915-A Ash
- NSL1915-C Charcoal
- NSL1915-D Sand
- NSL1915-E Earth
- NSL1915-F Forest
- NSL1915-G Sage
- NSL1915-O Ocean
- NSL1915-P Pearl
- NSL1915-S Slate
- NSL1915-T Terracotta

PRODUCT DETAILS

- 19.5" x 15" x 4.5" OD (495mm x 381mm x 114mm)
- 17.5" x 13" x 3.75" ID (445mm x 330mm x 95mm)
- 1.75" (43mm) drain opening
- Handcrafted from sustainable NativeStone
- Sealed with NativeStone Shield™
- Weight: approx. 44lbs

INSTALLATION

- Vessel, Undermount, or Apron-Front

COORDINATING PRODUCTS

- Drains: DR120, DR130 or DR150
- UK1426 Undermount Kit

STANDARDS COMPLIANCE

- UPC/cUPC compliant
- ADA compliant if undermounted

IMPORTANT

Do NOT use tape or other adhesives on NativeStone as it may remove the sealer.

Due to the handcrafted nature of this product, it will vary in finish, texture, and other details. Dimensions may vary up to ¼" (6mm). We strongly recommend waiting for the actual product before making any installation cuts.