

SPECIFICATIONS

MANHATTAN

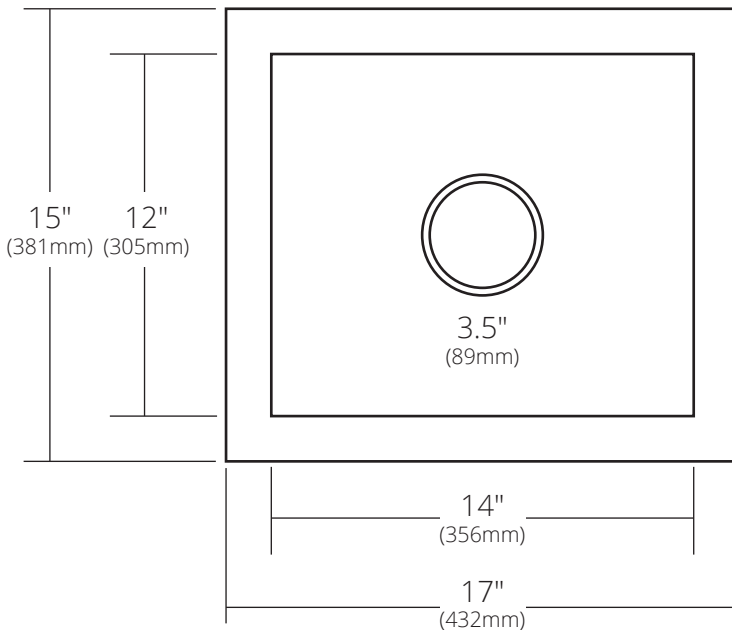

TOP VIEW



SIDE VIEW

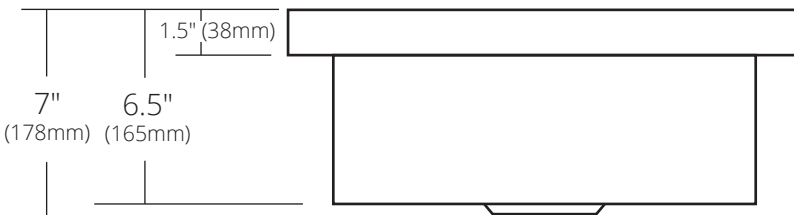

- CPS232 Antique
- CPS432 Polished Copper
- CPS532 Brushed Nickel
- CPS832 Polished Nickel

PRODUCT DETAILS

- 17" x 15" x 7" OD (432mm x 381mm x 178mm)
- 14" x 12" x 6.5" ID (356mm x 305mm x 165mm)
- Hand hammered 16 gauge recycled copper
- 3.5" (89mm) drain opening

INSTALLATION

- Drop-In

COORDINATING PRODUCTS

- Drains: DR320 or DR340

STANDARDS COMPLIANCE

- UPC/cUPC compliant

IMPORTANT

Due to the handcrafted nature of this product, it will vary in finish, texture, hammering, and other details. Dimensions may vary up to 1/4" (6mm). We strongly recommend waiting for the actual product before making any installation cuts.