

*SPECIFICATIONS*

**FARMHOUSE QUARTET**

*NativeStone® Collection*



TOP VIEW

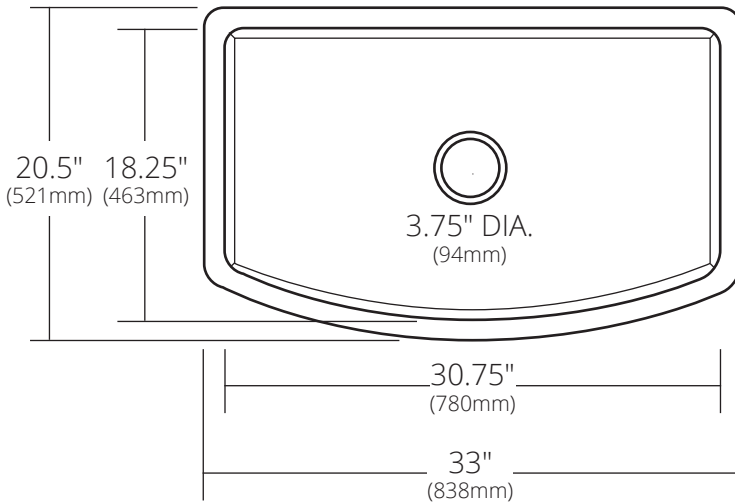

FRONT VIEW

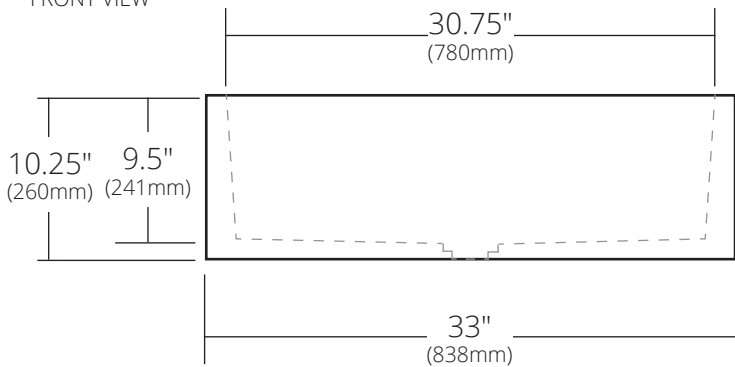

- NSKQ3320-A Ash
- NSKQ3320-C Charcoal
- NSKQ3320-D Sand
- NSKQ3320-E Earth
- NSKQ3320-P Pearl
- NSKQ3320-S Slate

**PRODUCT DETAILS**

- 33" x 20.5" x 10.25" OD (838mm x 521mm x 260mm)
- 30.75" x 18.25" x 9.5" ID (780mm x 463mm x 241mm)
- 3.75" (94mm) drain opening
- Handcrafted from sustainable NativeStone
- Sealed with NativeStone Shield™
- Weight: approx. 107lbs

**INSTALLATION**

- Undermount or Apron Front

**COORDINATING PRODUCTS**

- Drains: DR320 or DR340
- Bottom Grid: GRD2815
- UK2547 Undermount Kit

**STANDARDS COMPLIANCE**

- UPC/cUPC compliant

**IMPORTANT**

Do NOT use tape or other adhesives on NativeStone as it may remove the sealer.

Due to the handcrafted nature of this product, it will vary in finish, texture, and other details. Dimensions may vary up to 1/4" (6mm). We strongly recommend waiting for the actual product before making any installation cuts.