

SPECIFICATIONS

DREAMER 30

Fireclay Collection



FRK3018-W White

PRODUCT DETAILS

- 30" x 17.75" x 10" OD (762mm x 451mm x 252mm)
- 28" x 15.75" x 9.25" ID (713mm x 402mm x 233mm)
- 3.75" (94mm) drain opening
- Italian Fireclay
- Weight: approx. 99lbs

INSTALLATION

- Apron Front
- Install with negative reveal or flush mount

COORDINATING PRODUCTS

- Drains: DR320 or DR340
(extended flange not required)
- Bottom Grid: GRD2614
- UK2547 Undermount Kit

STANDARDS COMPLIANCE

- UPC/cUPC compliant

IMPORTANT

Due to the handcrafted nature of this product, dimensions may vary up to 1/2" (13mm). We strongly recommend waiting for the actual product before making any installation cuts.

TOP VIEW

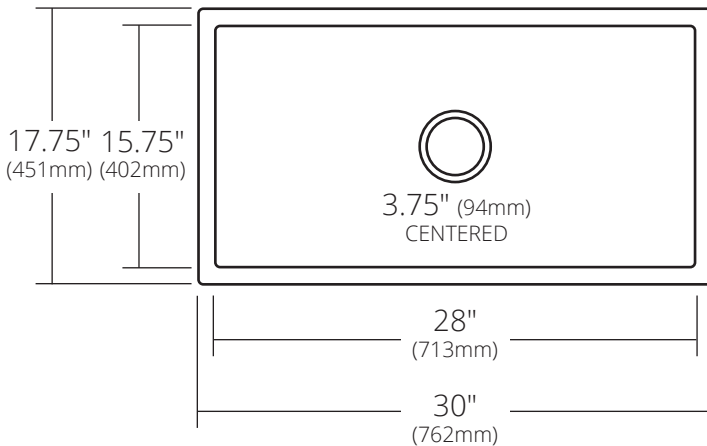

FRONT VIEW

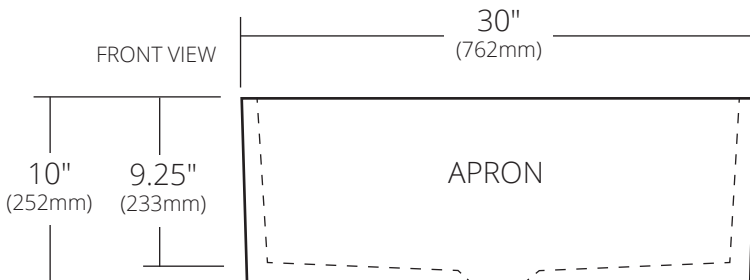

SIDE VIEW

