

SPECIFICATIONS

CUYAMA

NativeStone® Collection



TOP VIEW

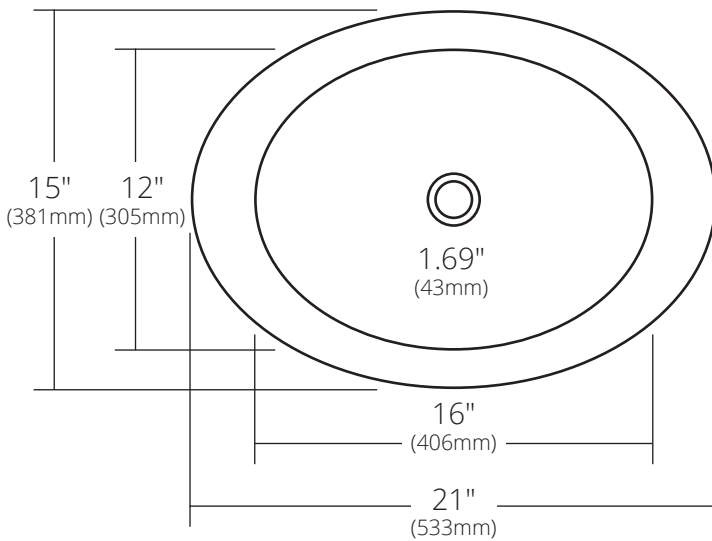

- NSL2115-A Ash
- NSL2115-C Charcoal
- NSL2115-D Sand
- NSL2115-E Earth
- NSL2115-F Forest
- NSL2115-G Sage
- NSL2115-O Ocean
- NSL2115-P Pearl
- NSL2115-S Slate
- NSL2115-T Terracotta

PRODUCT DETAILS

- 21" x 15" x 5" OD (533mm x 381mm x 127mm)
- 16" x 12" x 4.25" ID (406mm x 305mm x 108mm)
- 1.69" (43mm) drain opening for a 1.5" drain
- Handcrafted from sustainable NativeStone
- Sealed with NativeStone Shield™
- Weight: approx. 14lbs

INSTALLATION

- Drop-In

COORDINATING PRODUCTS

- Drains: DR120, DR130 or DR150
- Vanity Top Cutout: -O1714

STANDARDS COMPLIANCE

- UPC/cUPC compliant



IMPORTANT

Do NOT use tape or other adhesives on NativeStone as it may remove the sealer.

Due to the handcrafted nature of this product, it will vary in finish, texture, and other details. Dimensions may vary up to ¼" (6mm). We strongly recommend waiting for the actual product before making any installation cuts.

SIDE VIEW

