

SPECIFICATIONS

ARCATA 48

NativeStone® Collection

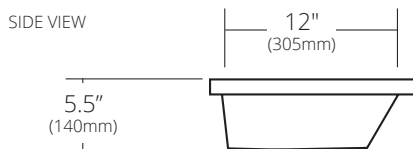
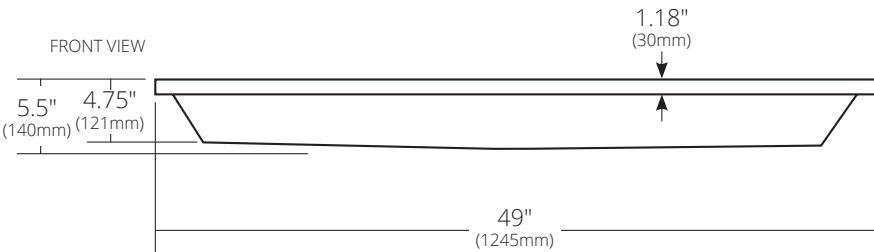
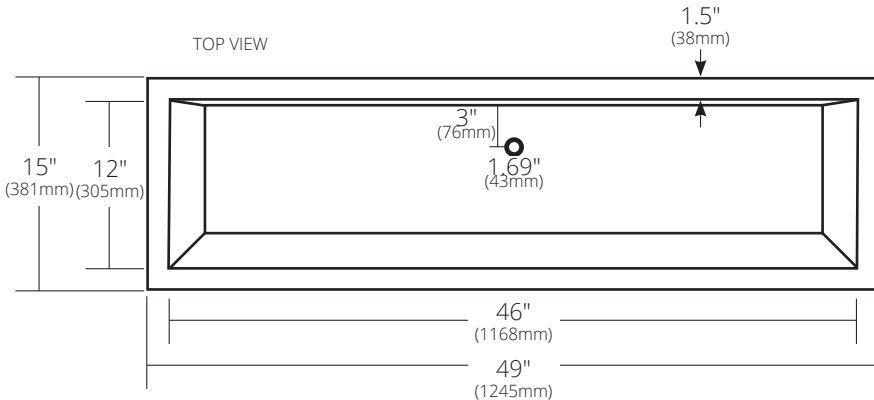

- | | |
|--------------------|-----------------------|
| NSL4915-A Ash | NSL4915-G Sage* |
| NSL4915-C Charcoal | NSL4915-O Ocean* |
| NSL4915-D Sand | NSL4915-P Pearl |
| NSL4915-E Earth | NSL4915-S Slate |
| NSL4915-F Forest* | NSL4915-T Terracotta* |

*Made to Order

PRODUCT DETAILS

- 49" x 15" x 5.5" OD (1245mm x 381mm x 140mm)
- 46" x 12" x 4.75" ID (1168mm x 305mm x 121mm)
- 1.69" (43mm) drain opening to fit 1.75" drain
- Handcrafted from sustainable NativeStone
- Sealed with NativeStone Shield™
- Weight: approx. 60lbs

INSTALLATION

- Undermount

COORDINATING PRODUCTS

- Drains: DR120, DR130 or DR150
- UK1426 Undermount Kit

STANDARDS COMPLIANCE

- UPC/cUPC compliant

IMPORTANT

Do NOT use tape or other adhesives on NativeStone as it may remove the sealer.

Due to the handcrafted nature of this product, it will vary in finish, texture, and other details. Dimensions may vary up to ¼" (6mm). We strongly recommend waiting for the actual product before making any installation cuts.